

## Cool MOS™ Power Transistor

- New revolutionary high voltage technology
- Worldwide best  $R_{DS(on)}$  in TO 247
- Ultra low gate charge
- Periodic avalanche rated
- Extreme  $dv/dt$  rated
- Optimized capacitances
- Improved noise immunity

### Product Summary

$V_{DS} @ T_{jmax}$	650	V
$R_{DS(on)}$	0.07	$\Omega$
$I_D$	47	A

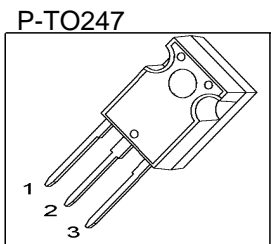

Type	Package	Ordering Code	Marking
SPW47N60S5	P-TO247	Q67040-S4240	47N60S5

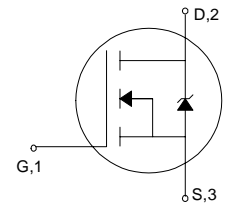

### Maximum Ratings, at $T_C = 25^\circ\text{C}$ , unless otherwise specified

Parameter	Symbol	Value	Unit
Continuous drain current	$I_D$		A
$T_C=25^\circ\text{C}$		47	
$T_C=100^\circ\text{C}$		30	
Pulsed drain current <sup>1)</sup>	$I_{D \text{ puls}}$	94	
$T_C=25^\circ\text{C}$			
Avalanche energy, single pulse	$E_{AS}$	1800	mJ
$I_D = 10 \text{ A}, V_{DD} = 50 \text{ V}$			
Avalanche energy (repetitive, limited by $T_{jmax}$ )	$E_{AR}$	1	
$I_D = 20 \text{ A}, V_{DD} = 50 \text{ V}$			
Avalanche current (repetitive, limited by $T_{jmax}$ )	$I_{AR}$	20	A
Reverse diode $dv/dt$	$dv/dt$	6	kV/ $\mu\text{s}$
$I_S=47\text{A}, V_{DS}<V_{DSS}, di/dt=100\text{A}/\mu\text{s}, T_{jmax}=150^\circ\text{C}$			
Gate source voltage	$V_{GS}$	$\pm 20$	V
Power dissipation	$P_{tot}$	415	W
$T_C=25^\circ\text{C}$			
Operating and storage temperature	$T_j, T_{stg}$	-55... +150	$^\circ\text{C}$

**Electrical Characteristics**, at  $T_j = 25\text{ }^\circ\text{C}$ , unless otherwise specified

Parameter	Symbol	Values			Unit
		min.	typ.	max.	

**Thermal Characteristics**

Thermal resistance, junction - case	$R_{thJC}$	-	-	0.3	K/W
Thermal resistance, junction - ambient (Leaded and through-hole packages)	$R_{thJA}$	-	45	-	

**Static Characteristics**, at  $T_j = 25\text{ }^\circ\text{C}$ , unless otherwise specified

Drain-source breakdown voltage $V_{GS} = 0\text{ V}$ , $I_D = 0.25\text{ mA}$	$V_{(BR)DSS}$	600	-	-	V
Gate threshold voltage, $V_{GS} = V_{DS}$ $I_D = 2.7\text{ mA}$ , $T_j = 25\text{ }^\circ\text{C}$	$V_{GS(th)}$	3.5	4.5	5.5	
Zero gate voltage drain current, $V_{DS} = V_{DSS}$ $V_{GS} = 0\text{ V}$ , $T_j = 25\text{ }^\circ\text{C}$ $V_{GS} = 0\text{ V}$ , $T_j = 150\text{ }^\circ\text{C}$	$I_{DSS}$	-	0.5	25	$\mu\text{A}$
		-	-	250	
Gate-source leakage current $V_{GS} = 20\text{ V}$ , $V_{DS} = 0\text{ V}$	$I_{GSS}$	-	-	100	nA
Drain-source on-state resistance $V_{GS} = 10\text{ V}$ , $I_D = 30\text{ A}$	$R_{DS(on)}$	-	0.06	0.07	$\Omega$

<sup>1</sup>current limited by  $T_{jmax}$

**Electrical Characteristics**, at  $T_j = 25\text{ }^\circ\text{C}$ , unless otherwise specified

Parameter	Symbol	Conditions	Values			Unit
			min.	typ.	max.	

**Dynamic Characteristics**

Transconductance	$g_{fs}$	$V_{DS} \geq 2 \cdot I_D \cdot R_{DS(on)max}$ , $I_D = 30\text{A}$	-	30	-	S
Input capacitance	$C_{iss}$	$V_{GS} = 0\text{V}$ , $V_{DS} = 25\text{V}$ , $f = 1\text{MHz}$	-	7600	-	pF
Output capacitance	$C_{oss}$		-	2900	-	
Reverse transfer capacitance	$C_{rss}$		-	27	-	
Turn-on delay time	$t_{d(on)}$	$V_{DD} = 350\text{V}$ , $V_{GS} = 10\text{V}$ , $I_D = 47\text{A}$ , $R_G = 1.3\Omega$	-	360	-	ns
Rise time	$t_r$		-	30	-	
Turn-off delay time	$t_{d(off)}$		-	200	300	
Fall time	$t_f$		-	30	45	

**Gate Charge Characteristics**

Gate to source charge	$Q_{gs}$	$V_{DD} = 350\text{V}$ , $I_D = 47\text{A}$	-	56	-	nC
Gate to drain charge	$Q_{gd}$		-	123	-	
Total gate charge	$Q_g$	$V_{DD} = 350\text{V}$ , $I_D = 47\text{A}$ , $V_{GS} = 0$ to $10\text{V}$	-	220	286	

**Reverse Diode**

Inverse diode continuous forward current	$I_S$	$T_C = 25\text{ }^\circ\text{C}$	-	-	47	A
Inverse diode direct current, pulsed	$I_{SM}$		-	-	94	
Inverse diode forward voltage	$V_{SD}$	$V_{GS} = 0\text{V}$ , $I_F = 47\text{A}$	-	1	1.2	V
Reverse recovery time	$t_{rr}$	$V_R = 100\text{V}$ , $I_F = I_S$ , $di_F/dt = 100\text{A}/\mu\text{s}$	-	650	1100	ns
Reverse recovery charge	$Q_{rr}$		-	24	-	$\mu\text{C}$

**Power dissipation**

$$P_{tot} = f(T_C)$$

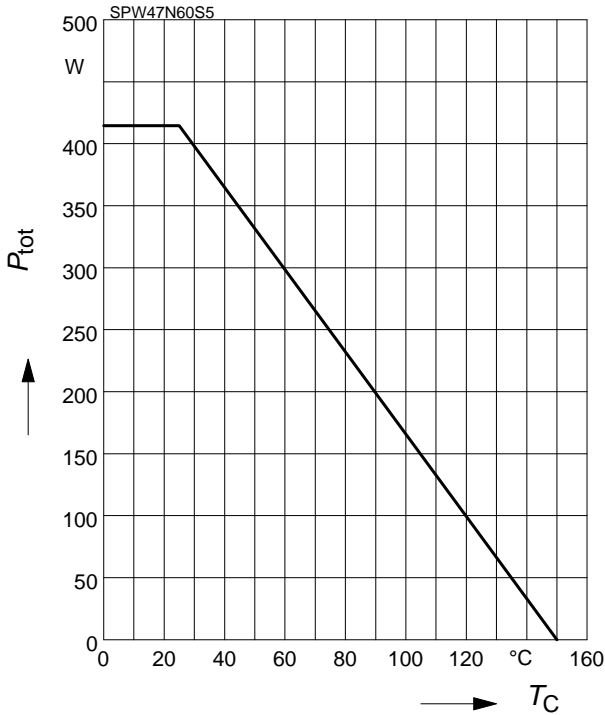

**Drain current**

$$I_D = f(T_C)$$

parameter:  $V_{GS} \geq 10\text{ V}$

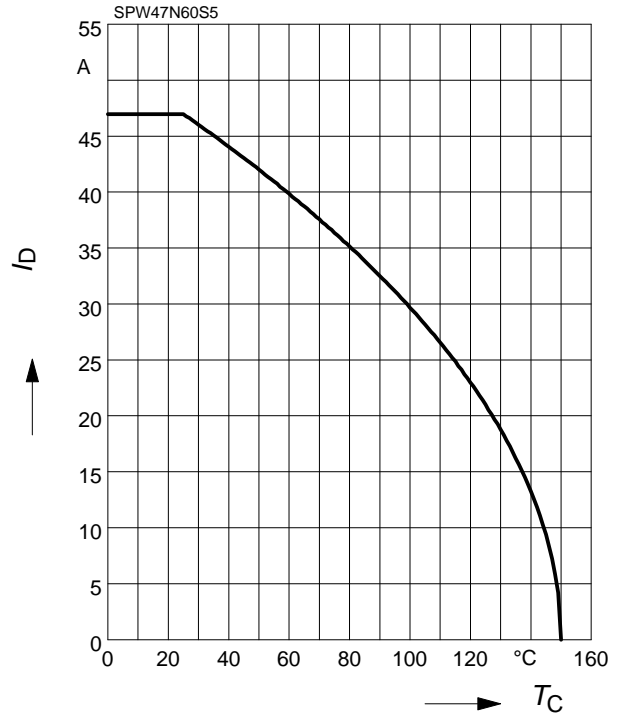

**Safe operating area**

$$I_D = f(V_{DS})$$

parameter:  $D=0.01, T_C=25^\circ\text{C}$

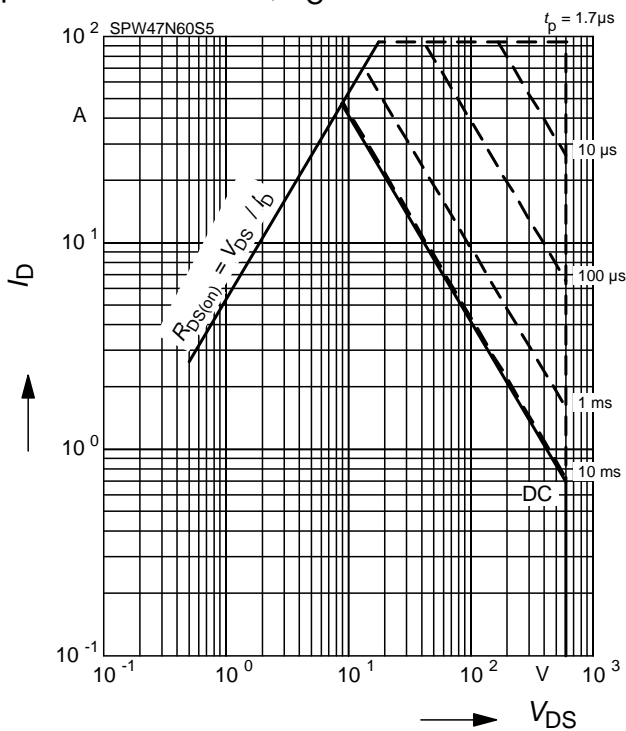

**Transient thermal impedance**

$$Z_{thJC} = f(t_p)$$

parameter:  $D = t_p/T$

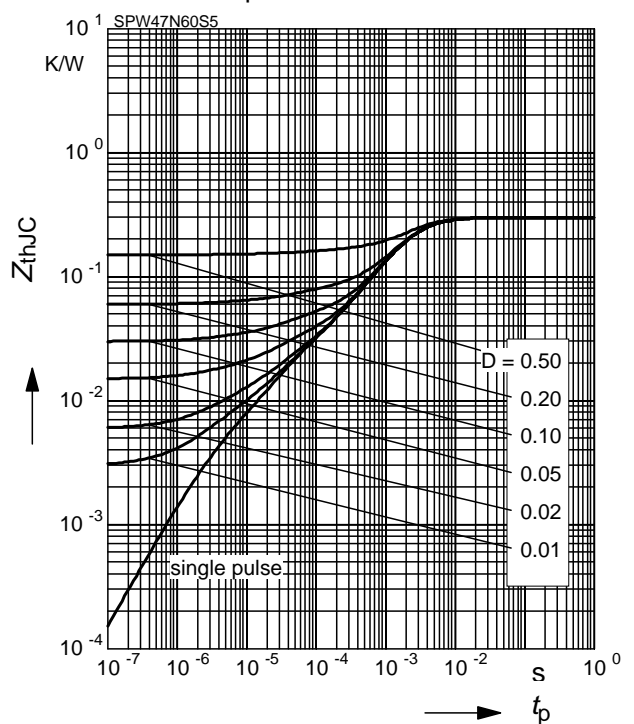

**Typ. output characteristic**

$$I_D = f(V_{DS})$$

Parameter:  $V_{GS}, T_j = 25\text{ }^\circ\text{C}$

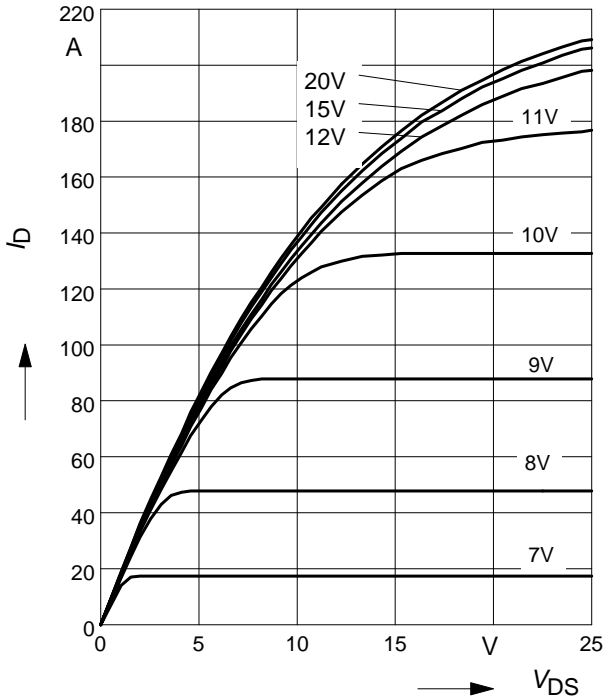

**Drain-source on-resistance**

$$R_{DS(on)} = f(T_j)$$

parameter:  $I_D = 30\text{ A}, V_{GS} = 10\text{ V}$

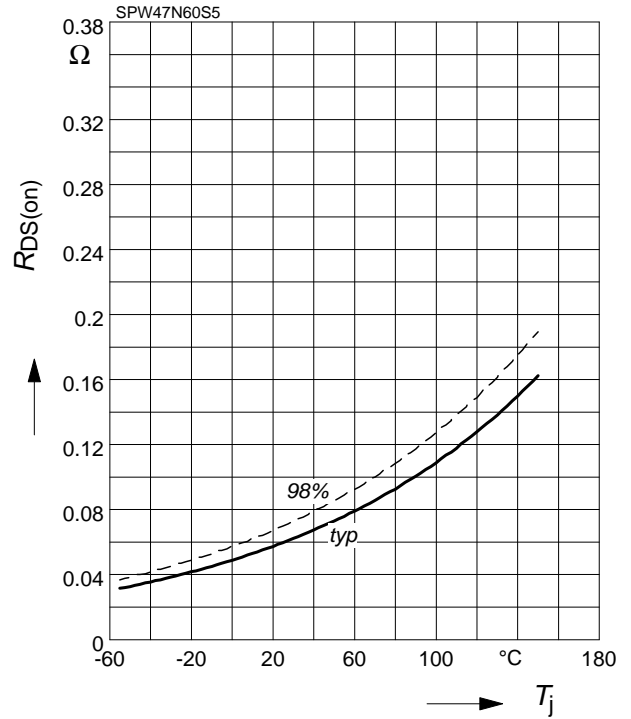

**Typ. transfer characteristics**

$$I_D = f(V_{GS})$$

$V_{DS} \geq 2 \times I_D \times R_{DS(on)max}$

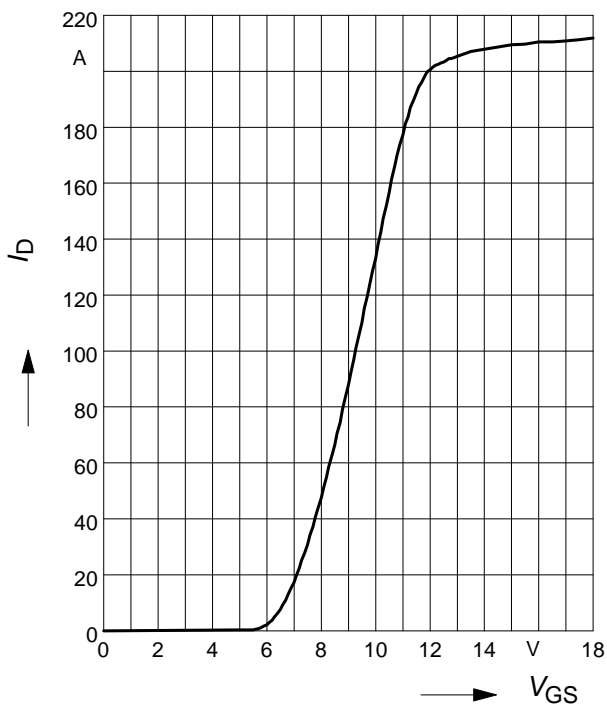

**Typ. capacitances**

$$C = f(V_{DS})$$

parameter:  $V_{GS} = 0\text{ V}, f = 1\text{ MHz}$

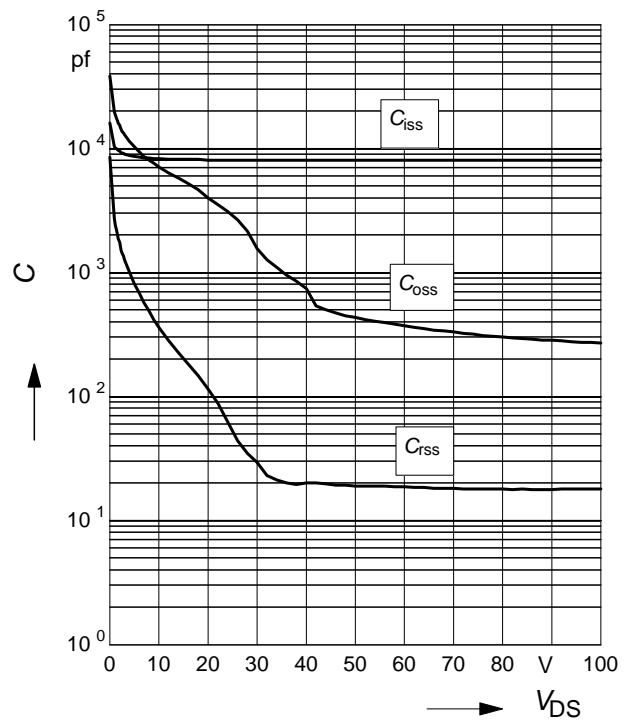

**Avalanche energy**

$$E_{AS} = f(T_j)$$

par.:  $I_D=10A, V_{DD}=50V$

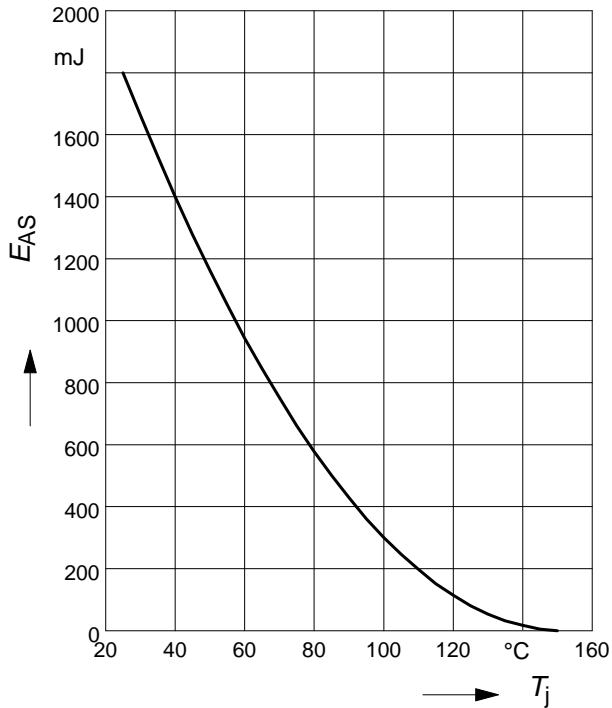

**Avalanche SOA**

$$I_{AR} = f(t_{AR})$$

par.:  $T_j \leq 150\text{ °C}$

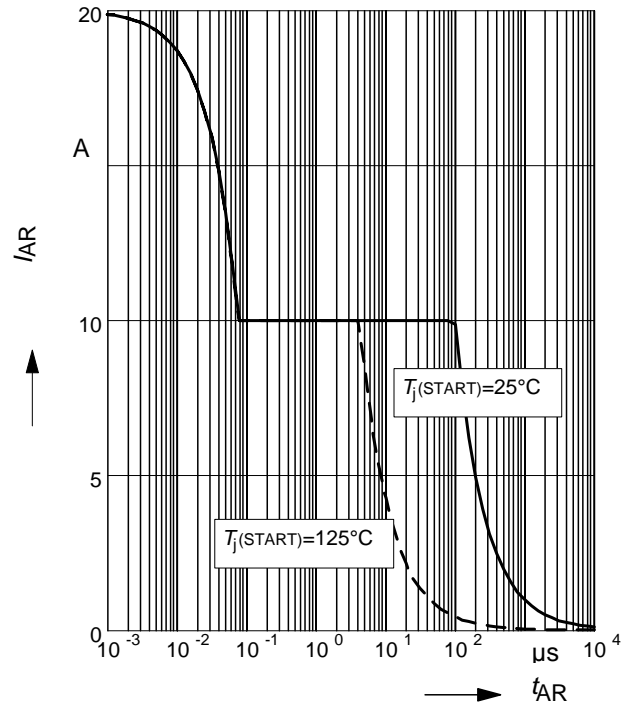

**Drain-source breakdown voltage**

$$V_{(BR)DSS} = f(T_j)$$

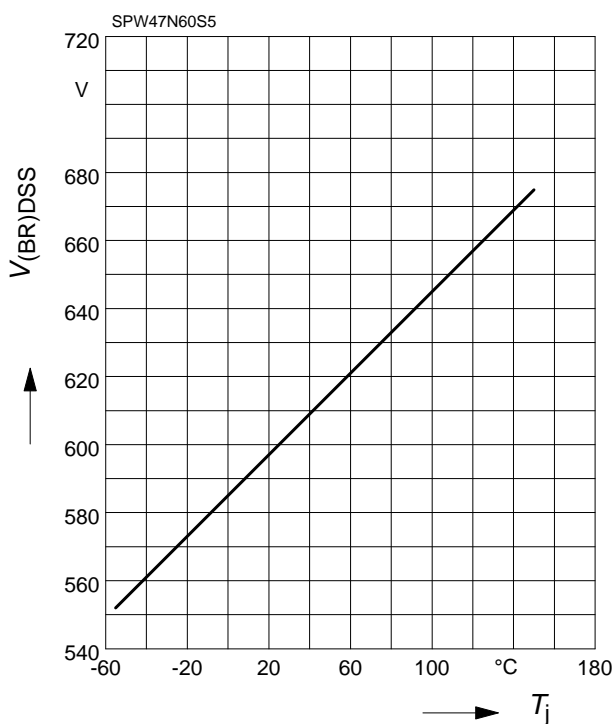

**Gate threshold voltage**

$$V_{GS(th)} = f(T_j)$$

parameter:  $V_{GS} = V_{DS}, I_D = 2.7\text{ mA}$

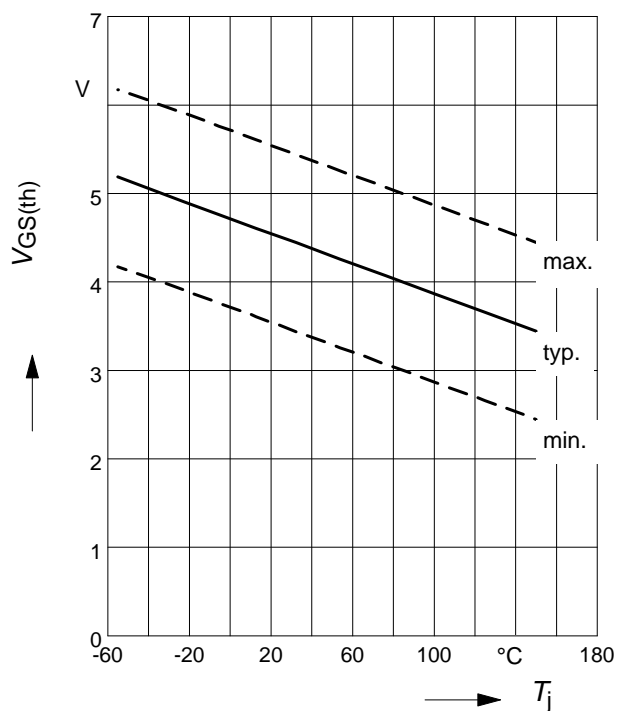

**Forward characteristics of reverse diode**

$$I_F = f(V_{SD})$$

parameter:  $T_j$ ,  $t_p = 10 \mu s$

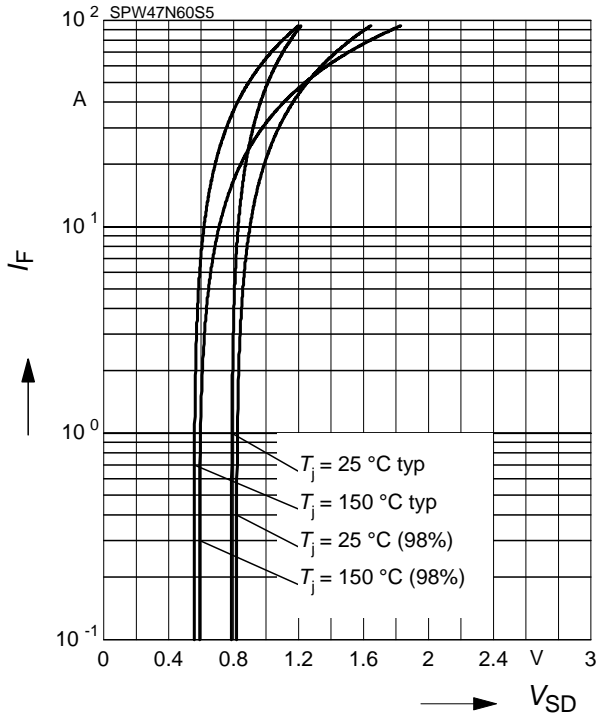

**Typ. gate charge**

$$V_{GS} = f(Q_{Gate})$$

parameter:  $I_{Dpuls} = 47 \text{ A}$

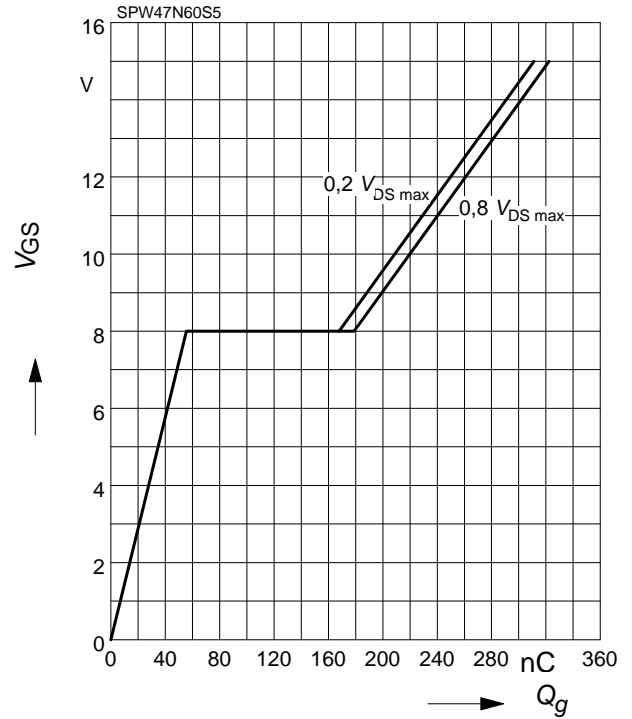

P-TO-247-3-1

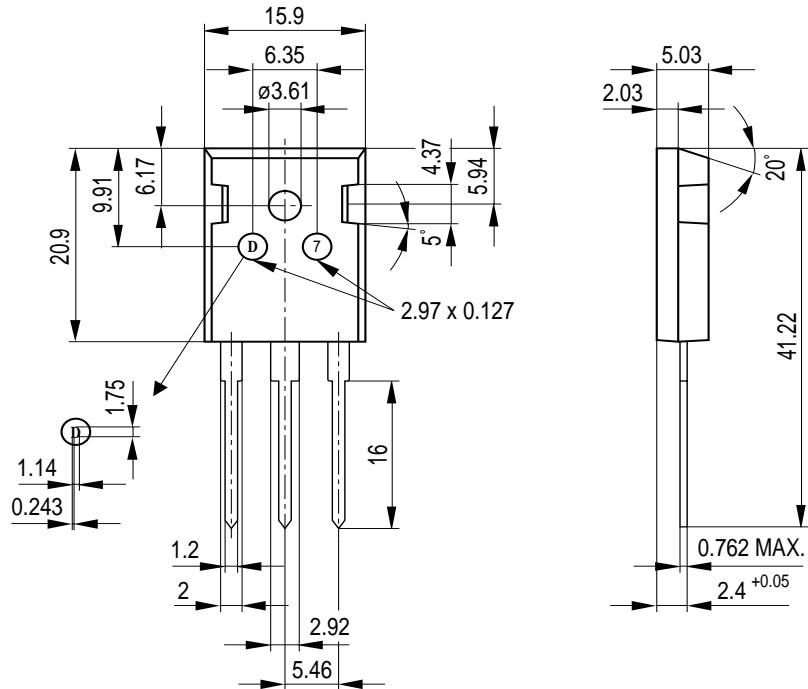

General tolerance unless otherwise specified: Leadframe parts:  $\pm 0.05$   
 Package parts:  $\pm 0.12$



**Published by**  
**Infineon Technologies AG,**  
**Bereichs Kommunikation**  
**St.-Martin-Strasse 53,**  
**D-81541 München**  
**© Infineon Technologies AG 1999**  
**All Rights Reserved.**

**Attention please!**

The information herein is given to describe certain components and shall not be considered as warranted characteristics.

Terms of delivery and rights to technical change reserved.

We hereby disclaim any and all warranties, including but not limited to warranties of non-infringement, regarding circuits, descriptions and charts stated herein.

Infineon Technologies is an approved CECC manufacturer.

**Information**

For further information on technology, delivery terms and conditions and prices please contact your nearest Infineon Technologies Office in Germany or our Infineon Technologies Representatives worldwide (see address list).

**Warnings**

Due to technical requirements components may contain dangerous substances.

For information on the types in question please contact your nearest Infineon Technologies Office.

Infineon Technologies Components may only be used in life-support devices or systems with the express written approval of Infineon Technologies, if a failure of such components can reasonably be expected to cause the failure of that life-support device or system, or to affect the safety or effectiveness of that device or system. Life support devices or systems are intended to be implanted in the human body, or to support and/or maintain and sustain and/or protect human life. If they fail, it is reasonable to assume that the health of the user or other persons may be endangered.